

ASTRO-SAFE

HVAC DUCT LINER & WRAP

VV Innvendig & Utvendig Kanalisolasjon

Miljøvennlig og energibesparende

Astro-Safe er laget av 100% polyester, termisk limt Hiloft Nonwoven Fiber, laminert til 99% ren forsterket aluminiumsfolie.

En lett overflate å rengjøre som opprettholder temperaturen i kanalene mellom syklusene. Dette øker trivselen for menneskene i bygget og reduserer driftstiden. Termisk ytelse økes og luftmotstanden reduseres.

VV Utvendig Kanalisolasjon

Varmeledningsevne Astrosafe 1" {25mm}

tm [C°]	23°	50°
(W/mK)	0,024	0,031



Astro-Safe...

- ...tilbyr vesentlig høyere verdier enn standard isolasjon per cm tykkelse.
- ...veier 75% mindre enn standard isolasjon.
- ...rullene inneholder 15,5 løpemetere.
- ...irriterer ikke øynene eller huden.
- ...er et "grønt" produkt.
- ...trenger ingen beskyttelse ved installasjon.
- ...vil ikke ta til seg fuktighet.
- ...tillater ikke at bakterier eller mugg gror fast i produktet.

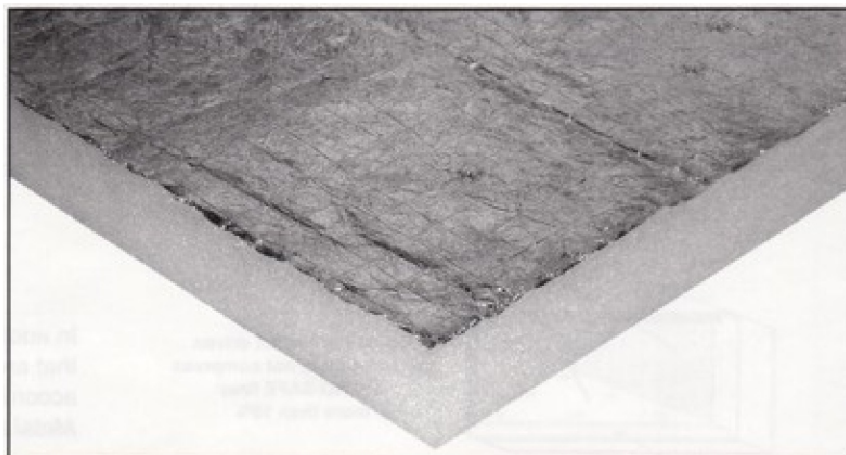

Isolasjon Brannklasse P1 - NT FIRE 036

Se Sintef-rapporten på www.astrofoil.no

VV Innvendig Kanalisolasjon

Lydabsorpsjon faktorer - ypperlig akustisk yteevne

frekvens (Hz)	25 mm
125	0,09
250	0,21
500	0,75
1000	1,09
1250	1,10

Spesifikasjoner

Reflektivitet	ASTM C1371	97%
Utstråling	ASTM C1371	3%
Varme overflate	ASTM C411	0 fordreining
Gjennomtrengning	ASTM C1104	0,9%
Sopp/bakteridannelse	ASTM G21,G22	0 vekst
UV Refleksjon	D & S Solar Reflectometer	>75%



ASTRO-SAFE

HVAC DUCT LINER & WRAP

Installasjonsguide

Orientation

ASTRO-SAFE duct liner must be installed with the reinforced foil facing toward the air stream.

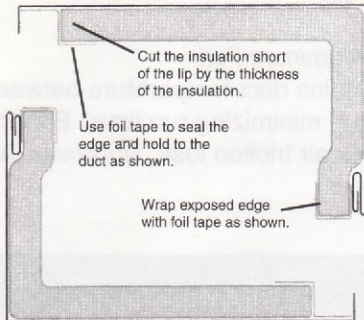

Adhesive

Use a Type 1 adhesive that complies with ASTM C 916. All duct surfaces that will be covered with ASTRO-SAFE must be covered 90% or more with adhesive. Installation must be neat and tight with no exposed edges.

Any exposed edges of ASTRO-SAFE that are not covered with foil must be coated with adhesive and taped with 2 mil foil tape with acrylic adhesive, such as ASTRO-FOIL tape.

Mechanical Fastening

In addition to an approved adhesive, mechanical fasteners that are welded or impact driven must be used in accordance with *HVAC Duct Construction Standards - Metal and Flexible* (SMACNA 1995).

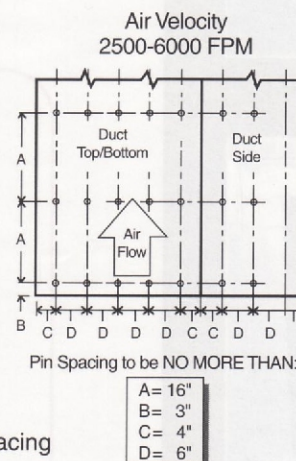
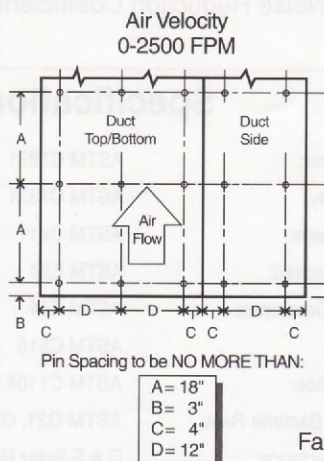
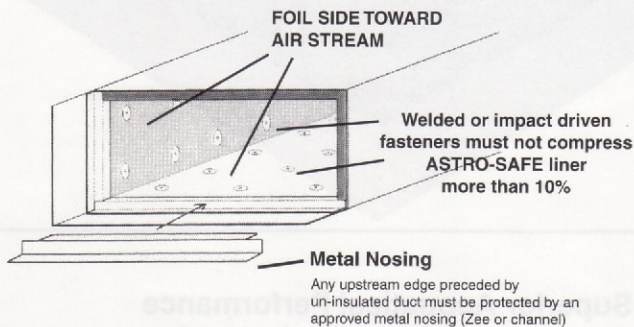

Fastener Spacing

Cuts or gouges in the foil surface can be repaired with 2 mil aluminum foil tape with an acrylic adhesive such as ASTRO-FOIL Foil Tape. Tape all seams where edges of ASTRO-SAFE butt together.